

REVISION HISTORY			
REV	DESCRIPTION	DATE	APPROVED
0	ECO-01967	6/11/2007	WSS
1	ECO-01978	6/19/2007	WSS
2	ECO-01994	7/12/2007	WSS
3	ECO-02939	8/6/2010	FED

Bill of Material						FILE NAME	REVISION
ITEM	PART NUMBER	STOCK NU	QTY	DESCRIPTION			
1	7803ESF243100		1	SPLIT DOORS FOR 78H x 24W E		I005600.iam	3
2	7217WSX200		6	STANDARD 2 - 75cfm FAN TRAY ASSEMBLY		7217WSX200.iam	6
3	XF02BUL		12	FAN GUARD 4" BLACK ZINC, KNIGHT #G109-15B-1		XF02BUL.ipt	1
4	8/32X3/4SCBLK		48	#8-32 x 3/4" LG BLACK OXIDE, WAX COAT, TYPE-F, PHIL. FLAT HEAD		8-32X750SCBLK.ipt	-
5	XF02IEC		6	2' BLACK CORD W/ IEC PLUG, 90° ANGLE, KNIGHT #28232-20-10		XF02IEC.ipt	

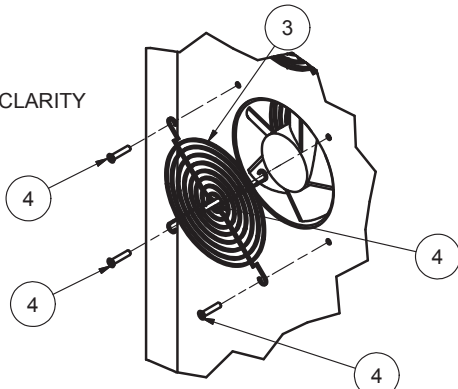

DETAIL A

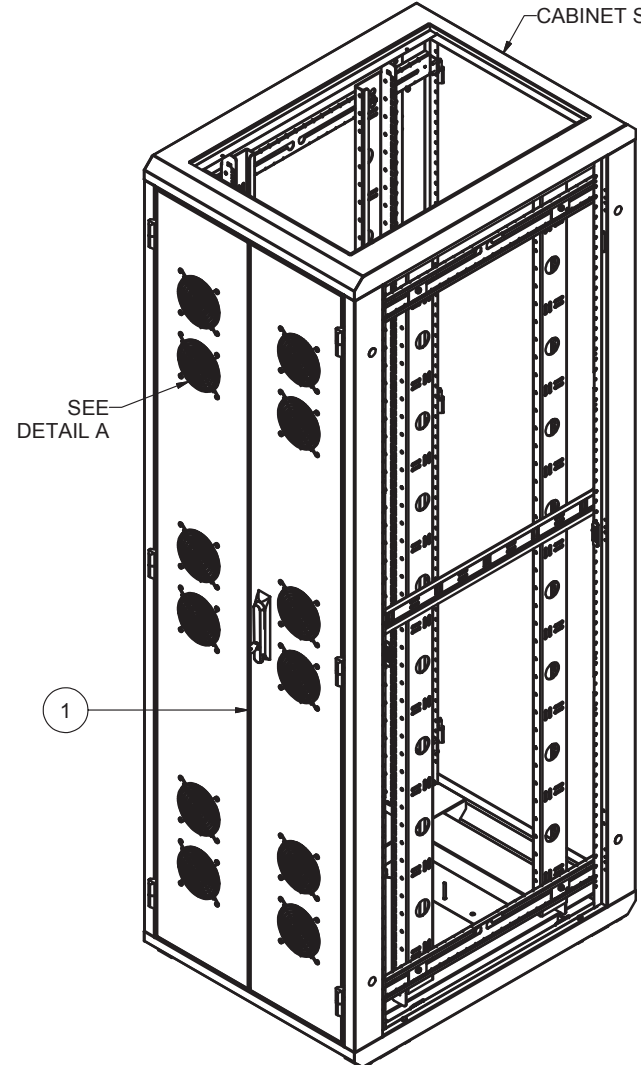
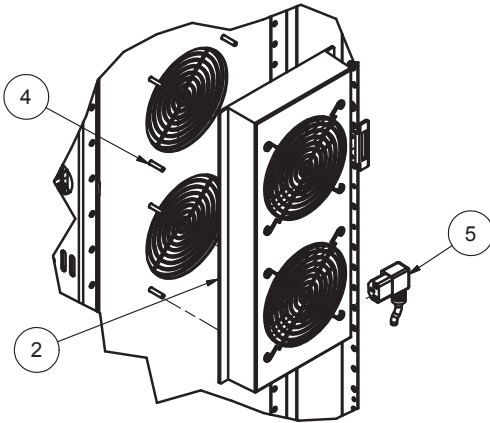

DETAIL B  
INSIDE OF DOOR

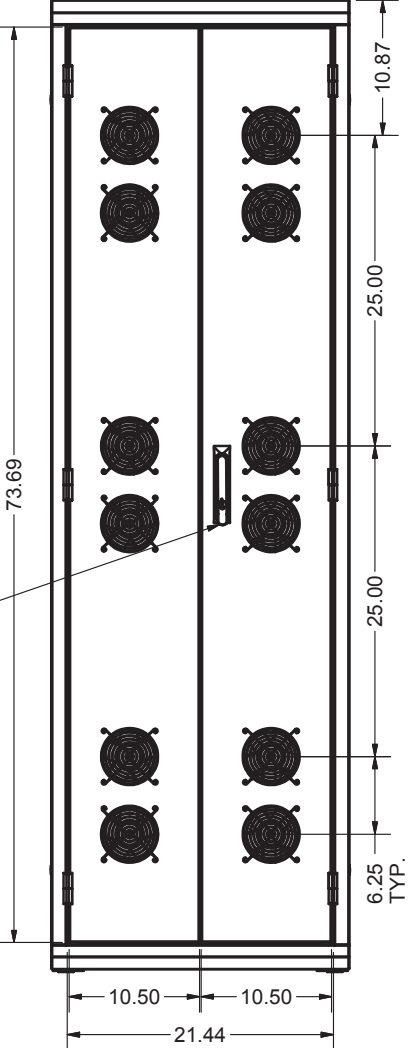
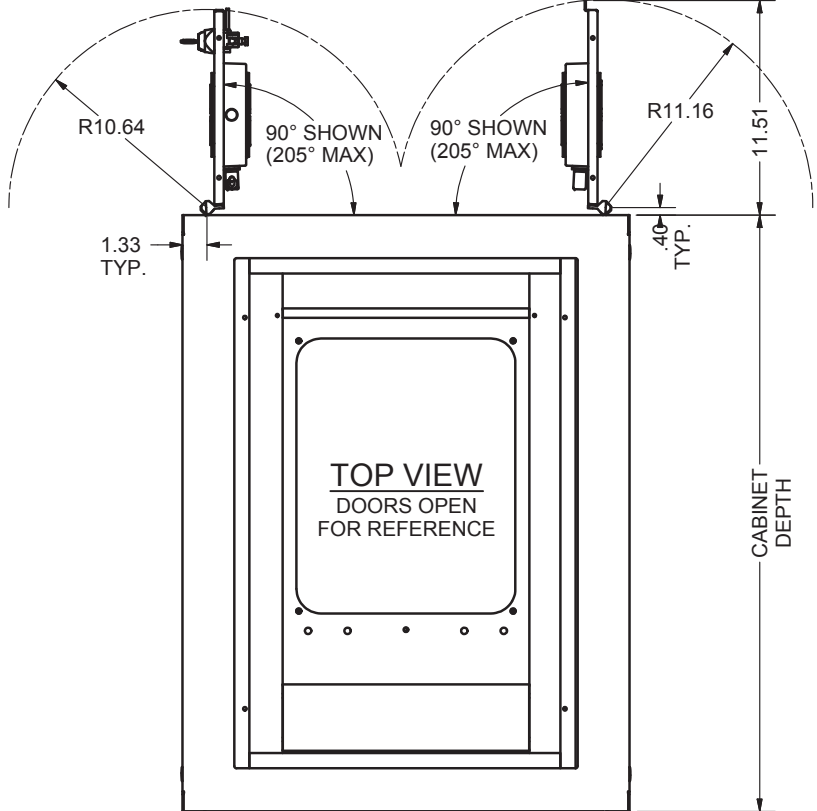

INTERPRET DRAWING PER ASME Y14.5M-1994  
 DIMENSIONAL LIMITS APPLY AFTER APPLICATION OF FINISH  
 DRAWING NOT TO SCALE  
 TOLERANCE UNLESS OTHERWISE NOTED:  
 ANGULAR +/- 1  
 .XXX +/- .010  
 .XX +/- .015  
 .X +/- .030  
 X FOR REF. ONLY  
 UNLESS OTHERWISE SPECIFIED ALL DIMENSIONS ARE IN INCHES

**NOTICE:**  
 Use of this document is subject to a confidentiality and nondisclosure agreement with Great Lakes Case & Cabinet Co., Inc. (GLCC) and may not be reproduced, disclosed or utilized in whole or in part without prior written authorization from GLCC.

PART NUMBER:	7803ESF24
QTY PER UNIT:	1
MATERIAL TYPE:	
MATERIAL GAUGE:	#16 GA
FINISH:	
DRAWN:	DW 6/11/07
CHECKED:	WSS 6/11/07

TITLE: **SPLIT DOOR SET, COMPLETE, FOR 78"H x 24"W ENHANCED ENCLOSURE**

**Great Lakes**  
*case & cabinet co., inc*

P.O. BOX 551 EDINBORO, PA 16412  
 PHONE (814) 734-7303 FAX (814) 734-3907 E-MAIL: glcc@greatcabinets.com

DWG NO: I005599 REV: 3 SHEET 1 OF 1