

REVISION HISTORY			
REV	DESCRIPTION	DATE	APPROVED
4	ECO-02787	2/15/2010	FED
5	ECO-03254	6/13/2011	FED

Bill of Material						
ITEM	PART NUMBER	STOCK NUMBER	QTY	DESCRIPTION	FILE NAME	REVISION
1			1	MOUNTING BRACKET FOR CM05	I004070.ipt	3
2	S01-001		5	CABLE RING FOR CM05 & CM09	I011591.ipt	3

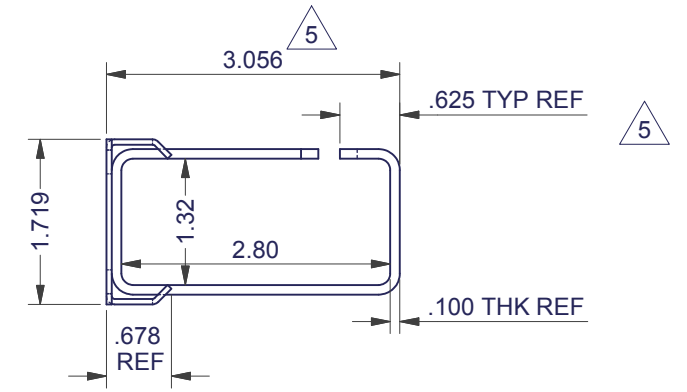
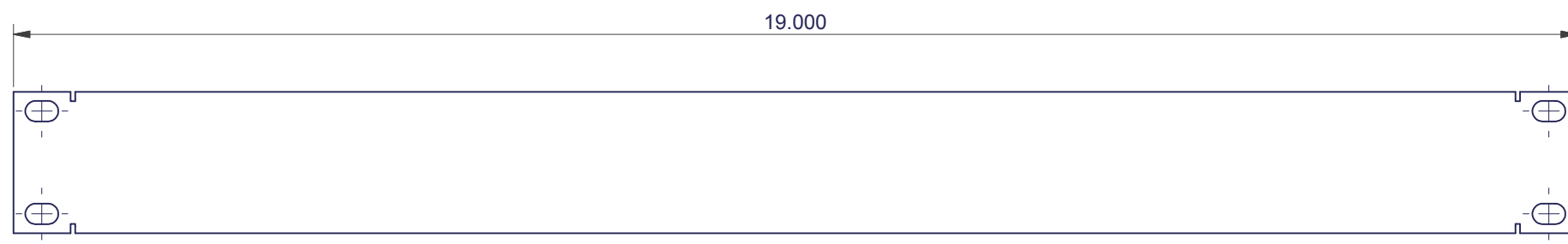
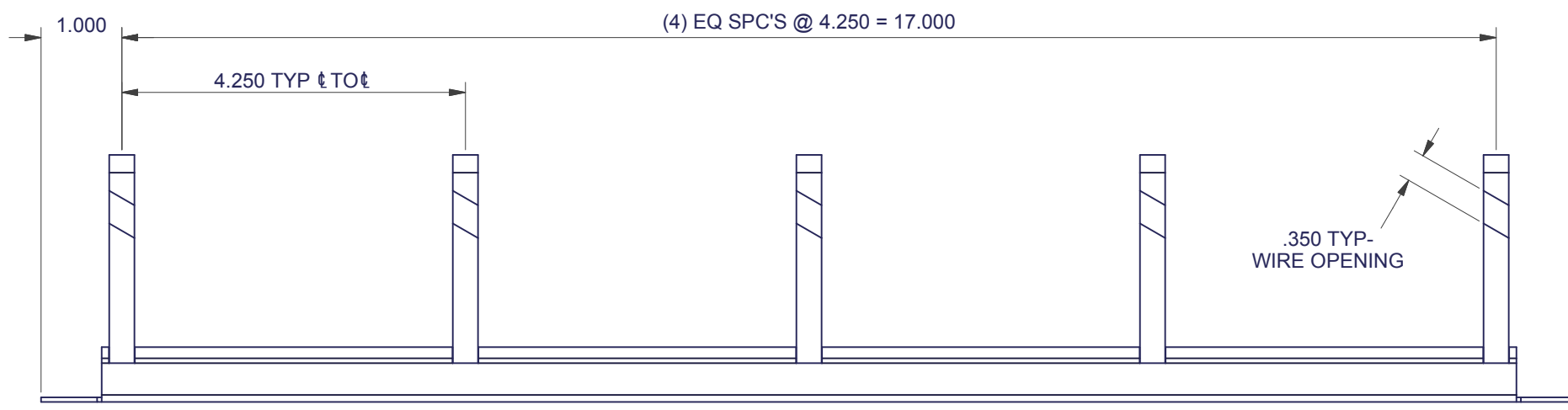
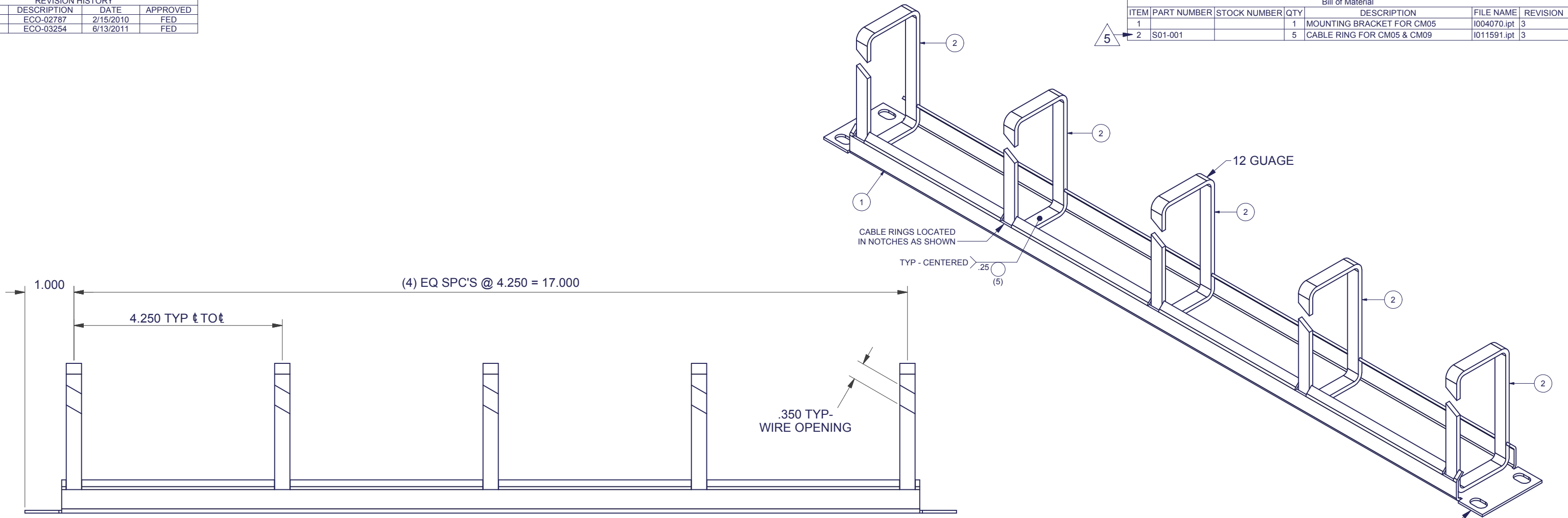

NOTES:

- DIMENSIONS APPLY BEFORE APPLICATION OF FINISH: ADD .005" TO EACH SURFACE FOR INSPECTION.**
- FINISH PER TD-09-103 (POWDER COAT), CLASS B, TEXTURE LEVEL 3, ALL SURFACES UNLESS OTHERWISE NOTED.**

INTERPRET DRAWING PER ASME Y14.5M-1994
DIMENSIONAL LIMITS APPLY AFTER APPLICATION OF FINISH
DRAWING NOT TO SCALE
TOLERANCE UNLESS OTHERWISE NOTED:
ANGULAR +/- 1°
.XXXX +/- .010
.XXX +/- .015
.XX +/- .030
.X FOR REF. ONLY
UNLESS OTHERWISE SPECIFIED ALL DIMENSIONS ARE IN INCHES

NOTICE:
Use of this document is subject to a confidentiality and nondisclosure agreement with Great Lakes Case & Cabinet Co., Inc. (GLCC) and may not be reproduced, disclosed or utilized in whole or in part without prior written authorization from GLCC.

PART NUMBER: CM05
QTY PER UNIT: 1
MATERIAL TYPE: CRS
MATERIAL GAUGE: SEE DETAILS
FINISH: SEE NOTES
DRAWN: FED
DATE: 2/15/2010
CHECKED & APP: WSS
DATE: 2/15/2010

TITLE: CABLE MANAGEMENT CM05 WELDMENT/ ASSEMBLY, 19" EIA MOUNTING
GREAT LAKES CASE & CABINET CO., INC. P.O. BOX 551 EDINBORO, PA 16412 PHONE (814) 734-7303 FAX (814) 734-3907 E-MAIL glcc@greatcabinets.com
DWG NO: 1011590
REV: 5
SHEET: 1 OF 1

