

REVISION HISTORY			
REV	DESCRIPTION	DATE	APPROVED
0	ECO-01991	7/10/2007	WSS

Bill of Material					
ITEM	PART NUMBER	QTY	DESCRIPTION	FILE NAME	REVISION
1	CMPX200	8	CABLE MANAGEMENT POST, 3"H (QTY. 1)	I005781.ipt	0
2	10/32X1SC23BLK	8	#10-32 x 1" PHIL PAN HEAD SCREW, TYPE 23, BLACK	10-32X1SC23BLK.ipt	-
3	10/32WING	8	#10-32 WING NUT 2ZN36616	10-32WING.ipt	-

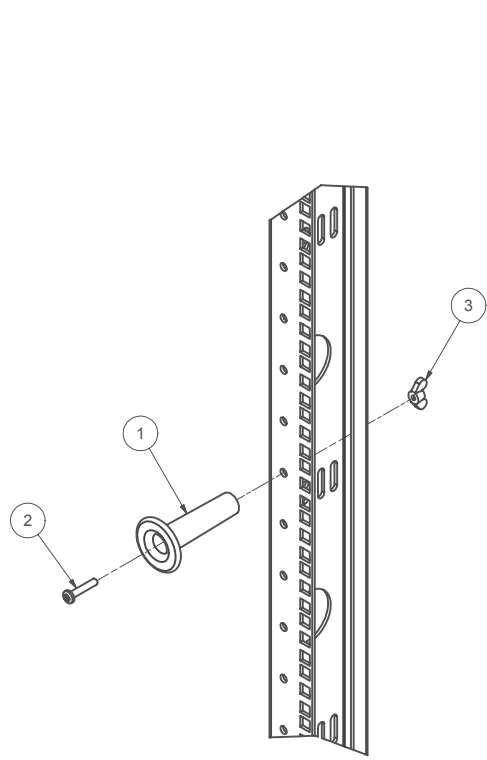

CMP INSTALLATION ON MOUNTING RAIL

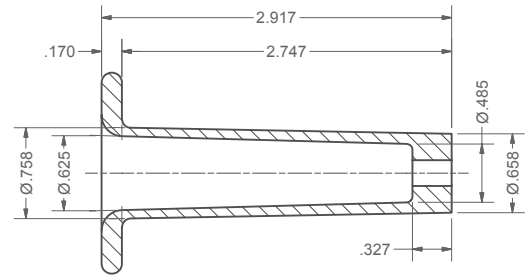
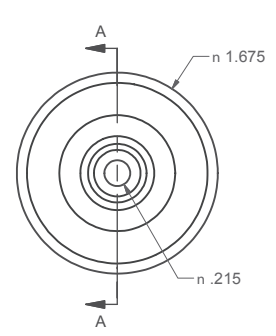
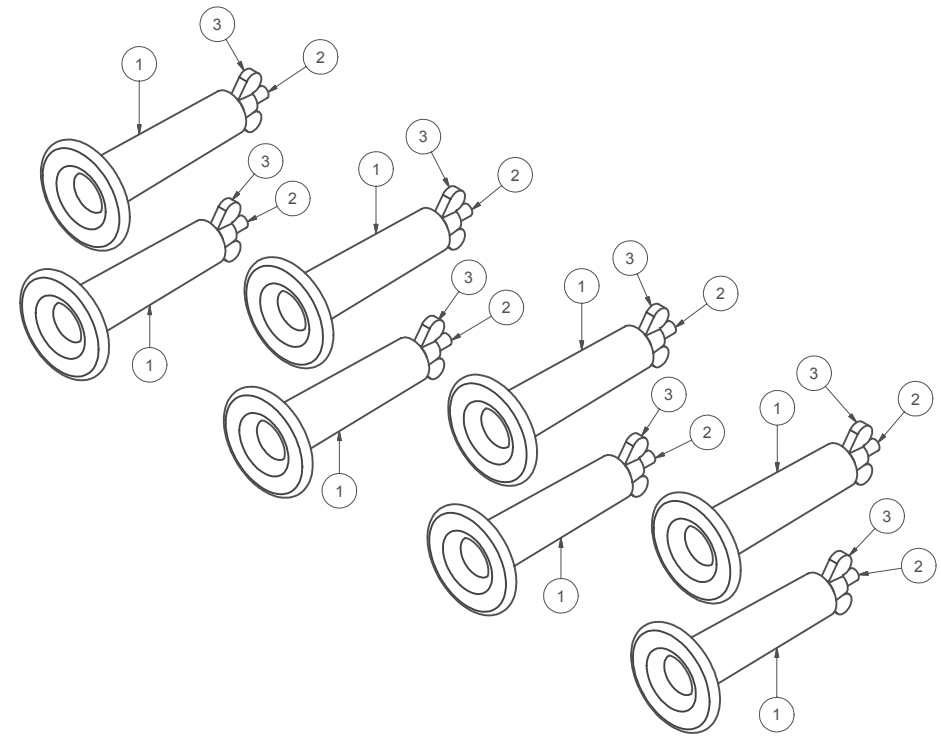

SECTION A-A

INTERPRET DRAWING PER ASME Y14.5M-1994
 DIMENSIONAL LIMITS APPLY AFTER APPLICATION OF FINISH
 DRAWING NOT TO SCALE
 TOLERANCE UNLESS OTHERWISE NOTED:
 ANGULAR +/- 1-
 .XXXX +/- .010
 .XXX +/- .015
 .XX +/- .030
 .X FOR REF. ONLY
 UNLESS OTHERWISE SPECIFIED ALL DIMENSIONS ARE IN INCHES

NOTICE:
 Use of this document is subject to a confidentiality and nondisclosure agreement with Great Lakes Case & Cabinet Co., Inc. (GLCC) and may not be reproduced, disclosed or utilized in whole or in part without prior written authorization from GLCC.

PART NUMBER:	CMP-8
QTY PER UNIT:	1
MATERIAL TYPE:	-
MATERIAL GAUGE:	-
FINISH:	-
DRAWN:	DavidW 7/10/07
CHECKED:	WSS 7/10/07

TITLE		CABLE MANAGEMENT POST, 3"H (QTY. 8),	
		P.O. BOX 551 EDINBORO, PA 16412	
		PHONE (814) 734-7303 FAX (814) 734-3907 E-MAIL: glcc@greatcabinets.com	
DWG NO:	I005782	REV	0
		SHEET 1 OF 1	