

REVISION HISTORY			
REV	DESCRIPTION	DATE	APPROVED
0	ECO-01377	3/25/2004	WSS
1	ECO-02804	3/4/2010	JL
2	ECO-03175	3/28/2011	FED

Bill of Material					DESCRIPTION	FILE NAME	REV
ITEM	PART NUMBER	STOCK NU	QTY				
1			1	GROUND WIRE ASSY, 48"L	I013624.iam	0	
2			5	GROUND WIRE ASSY, 24"L	I013622.iam	0	
3	M6FLWSHR		24	M6 ZINC-PLATED STEEL FLAT WASHER	M6FLWSHR.ipt	-	
4	M6NUT		24	M6 KEPS NUT	M6NUT.ipt	-	
5	H02-001	H02-001	24	#10-32 KEPS NUT, ZINC RoHS	10-32NUT.iam	-	

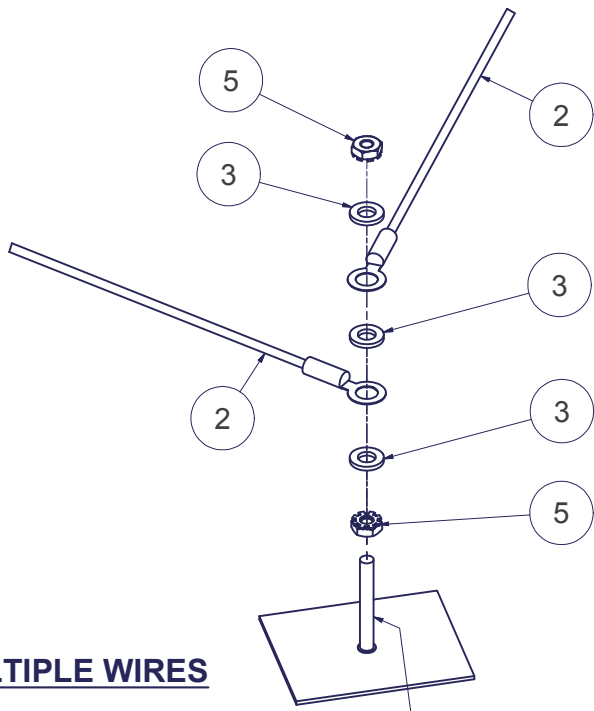

MULTIPLE WIRES

GROUND STUD: #10-32 x 1 7/8" LG or M6 x 50mm LG

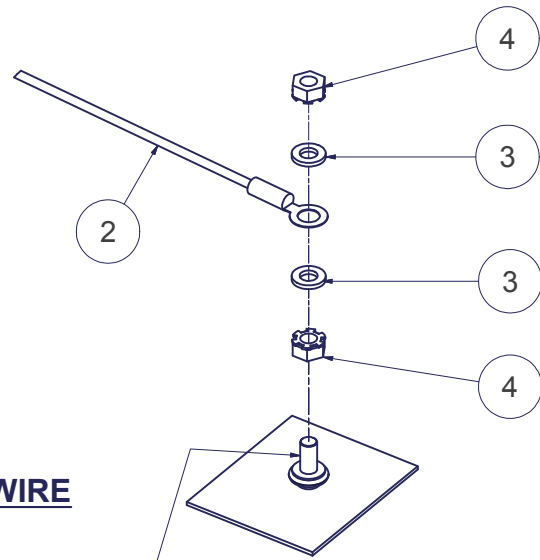
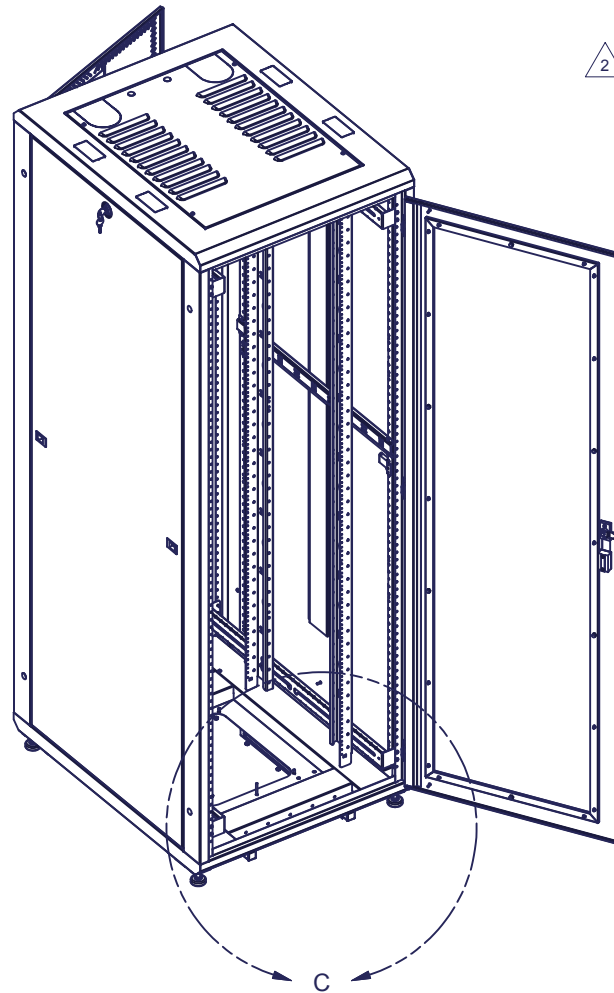

SINGLE WIRE

GROUND STUD: M6 x 13 LG, (CN-050CHBS) or #10-32 x 1/2" LG

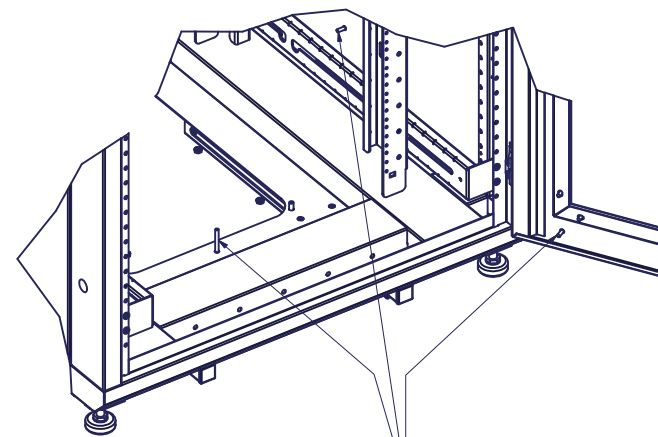

DETAIL C
REF - GROUND STUD
LOCATIONS NOT ALL SHOWN

- ② Using the Ground Wire Assemblies supplied, connect one end to a copper ground stud on each of the side panels and doors and the other end to copper ground stud located on the frame (or top) of the enclosure. (See Detail C)
- ② A longer Ground Wire Assembly has been included for 42" and 48" deep cabinets so that the front door can be connected to the ground stud when a side panel is not installed.
- ② Once all Ground Wire Assemblies have been connected to a copper frame stud, have at least one frame stud connected to the common building ground. (See Details for Multiple Straps and/or Single Strap)

IMPORTANT!
SEE NOTE 1
(SUBSTITUTE FOR
M6 KEPS NUTS
WHEN ENCLOSURE
HAS #10-32 STUDS)

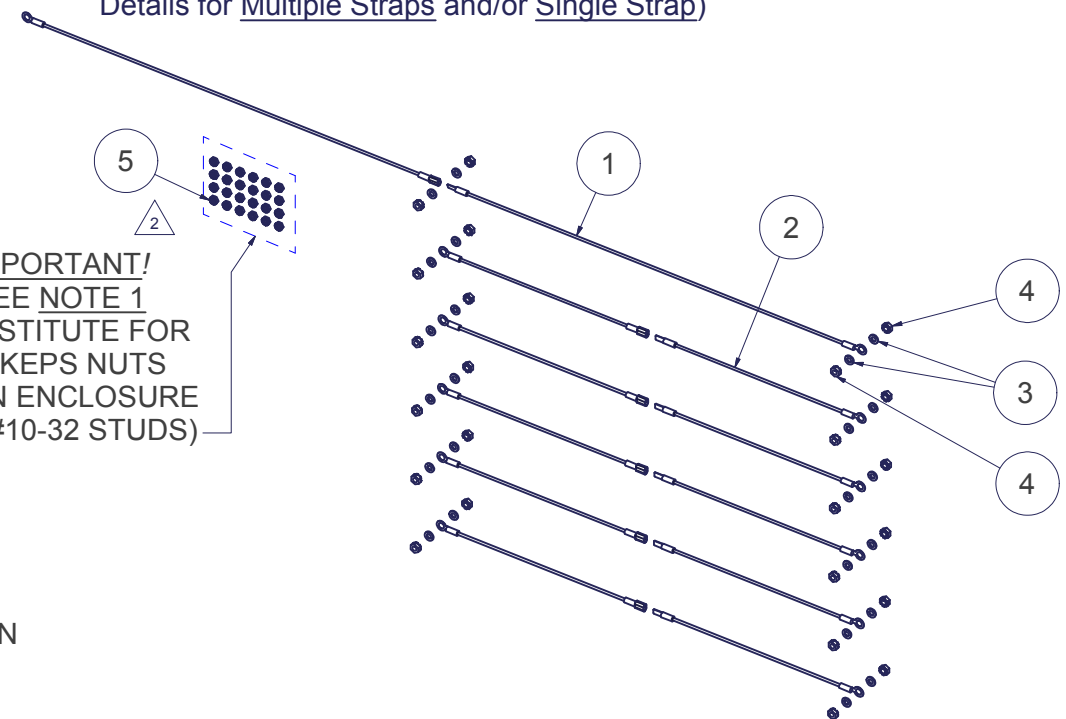

- NOTES:**
- ② 1) SORT HARDWARE & PLACE EACH SIZE & TYPE INTO IT'S OWN LABELED PLASTIC BAG.
 - ② 2) PACKAGING INSTRUCTIONS : SEAL ALL STRAPS & BAGGED HARDWARE WITH A COPY OF THIS DRAWING INTO A CLEAR PLASTIC BAG. APPLY SELF ADHESIVE PART No.(GR101) LABEL ONTO OUTSIDE OF BAG.

INTERPRET DRAWING PER ASME Y14.5M-1994
DIMENSIONAL LIMITS APPLY
AFTER APPLICATION OF FINISH
DRAWING NOT TO SCALE
TOLERANCE UNLESS OTHERWISE NOTED:
ANGULAR +/- .1°
.XXXX +/- .010
.XXX +/- .015
.XX +/- .030
.X FOR REF. ONLY

NOTICE:
Use of this document is subject to a confidentiality and nondisclosure agreement with Great Lakes Case & Cabinet Co., Inc. (GLCC) and may not be reproduced, disclosed or utilized in whole or in part without prior written authorization from GLCC.

PART NUMBER: GR101
QTY PER UNIT: 1
MATERIAL TYPE: SEE NOTES
MATERIAL GAUGE: SEE NOTES
FINISH: SEE NOTES
DRAWN: WSS 3/16/2003
CHECKED: j.a.l. 3/25/2003

TITLE: ENHANCED SERIES ENCLOSURE - GROUNDING KIT
Great Lakes Case & Cabinet Co., Inc.
P.O. BOX 551 EDINBORO, PA 16412
PHONE (814) 734-7303 FAX (814) 734-3907 E-MAIL: glcc@greatcabinets.com
DWG NO: 1002129
REV: 2
SHEET 1 OF 1

THIRD ANGLE PROJECTION