

REVISION HISTORY			
REV	DESCRIPTION	DATE	APPROVED
0	ECO-01870	2/19/2007	JL

Bill of Material					
ITEM	PART NUMBER	QTY	DESCRIPTION	FILE NAME	REV
1	10117-32728	1	Austin Hardware 10117-32728 Black Die cast Lock	10117-32728.iam	-
2	2000614	1	CAM FOR SIDE PANELS	2000614.ipt	-
3		1	60"H x 32"D ENHANCED, LIFT-OFF, VENTED SIDE PANEL	1005053.iam	0
4	A34062512	2	SOUTHCO SLIDE LATCH, FLUSH	A34062512.ipt	-

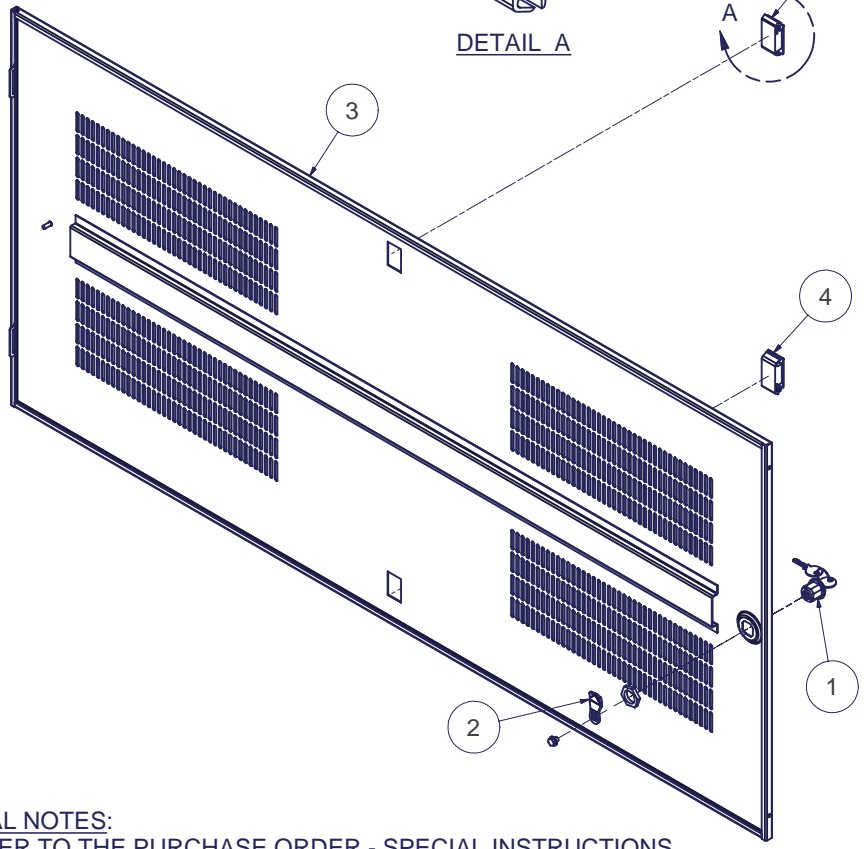
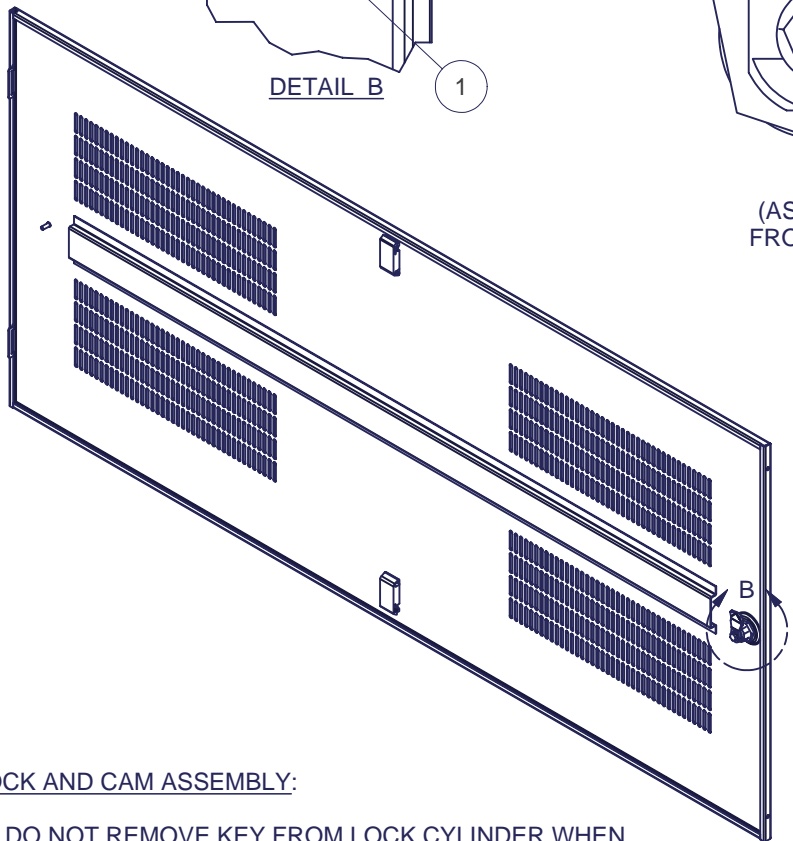
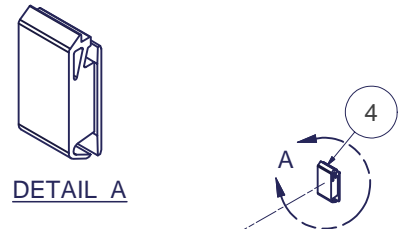
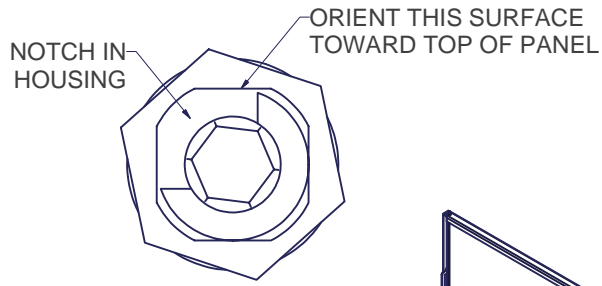
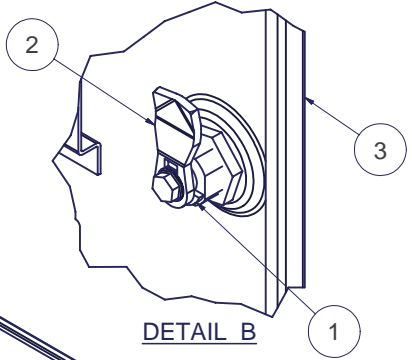

LOCK AND CAM ASSEMBLY:

- 1) DO NOT REMOVE KEY FROM LOCK CYLINDER WHEN CYLINDER IS NOT IN THE LOCK HOUSING, LOCK MECHANISM WILL BE DESTROYED.
- 2) POSITION LOCK HOUSING AS SHOWN IN VIEW 3 - NOTE ORIENTATION OF NOTCH ON ITS INSIDE SURFACE AND THE ORIENTATION OF THE KEY IN CYLINDER.
- 3) SECURE LOCK HOUSING WITH NUT.
- 4) POSITION CAM AS SHOWN AND SECURE WITH SCREW.
- 5) TURN KEY TO VERIFY SMOOTH OPERATION OF LOCK.

SPECIAL NOTES:

- 1) REFER TO THE PURCHASE ORDER - SPECIAL INSTRUCTIONS MAY APPLY.

INTERPRET DRAWING PER ASME Y14.5M-1994
DIMENSIONAL LIMITS APPLY AFTER APPLICATION OF FINISH
DRAWING NOT TO SCALE
TOLERANCE UNLESS OTHERWISE NOTED:
ANGULAR +/- 1°
.XXXX +/- .010
.XXX +/- .015
.XX +/- .030
.X FOR REF. ONLY
UNLESS OTHERWISE SPECIFIED ALL DIMENSIONS ARE IN INCHES

NOTICE:
Use of this document is subject to a confidentiality and nondisclosure agreement with Great Lakes Case & Cabinet Co., Inc. (GLCC) and may not be reproduced, disclosed or utilized in whole or in part without prior written authorization from GLCC.

PART NUMBER:	6011321ELLX100
QTY PER UNIT:	1
MATERIAL TYPE:	-
MATERIAL GAUGE:	-
FINISH:	-
DRAWN	DATE
JL	2/19/2007
CHECKED & APP.	DATE
WSS	2-19-07

TITLE	60"H x 32"D ENHANCED, LIFT OFF, VENTED SIDE PANEL ASSEMBLY		
GREAT LAKES CASE & CABINET CO., INC.			
P.O. BOX 551 EDINBORO, PA 16412			
PHONE (814) 734-7303 FAX (814) 734-3907			
E-MAIL glcc@greatcabinets.com			
DWG NO:	REV	SHEET: 1 OF 1	
1005052	0		



REVISION HISTORY			
REV	DESCRIPTION	DATE	APPROVED
0	ECO-01870	2/19/2007	JL

Bill of Material					
ITEM	PART NUMBER	QTY	DESCRIPTION	FILE NAME	REV
1	-	1	STIFFENER FOR 60"H SIDE PANELS - ECONOMY ENHANCED	1001675.ipt	0
2	101208260	1	#10-32 x 1/2"L WELD STUD (NELSON)	101208260.ipt	-
3	-	1	60"H x 32"D ENHANCED, LIFT-OFF, VENTED SIDE PANEL	1005053.ipt	0

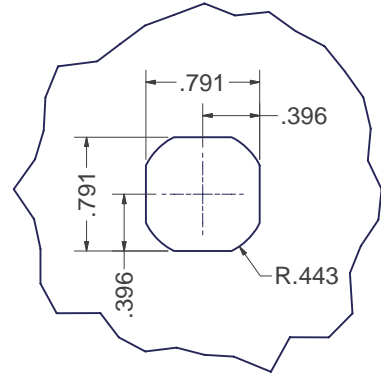
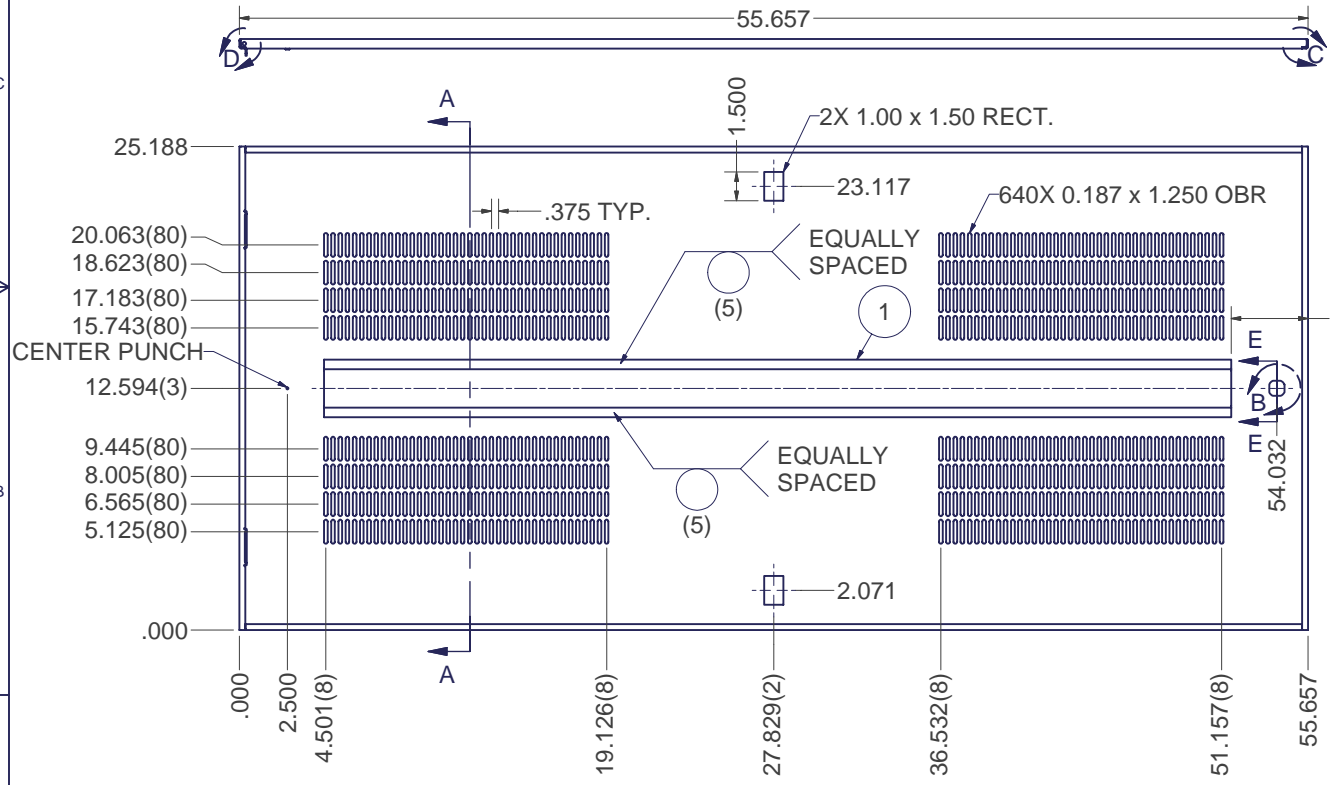
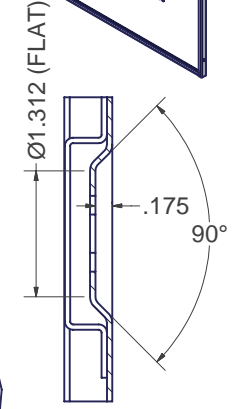
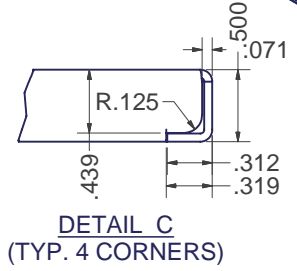
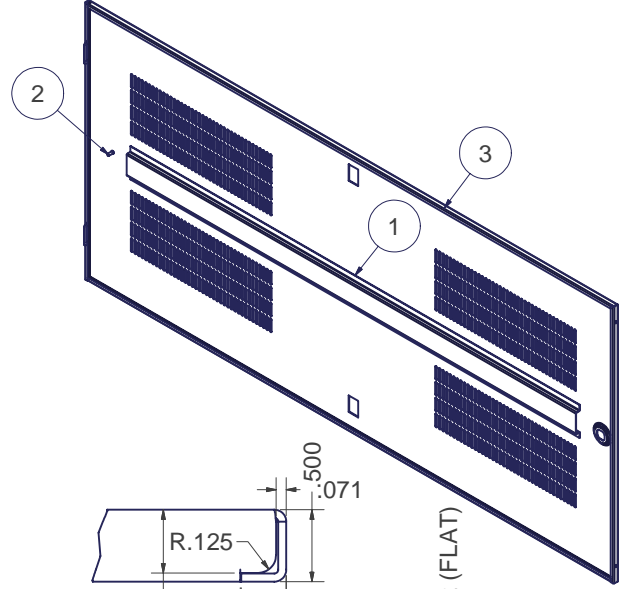
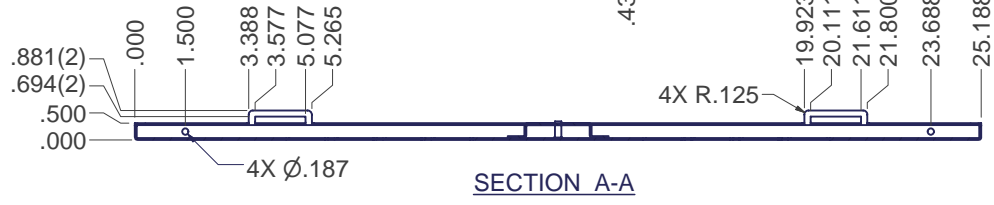
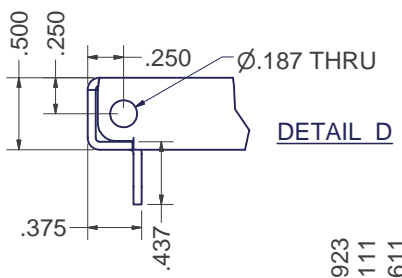

- SPECIAL NOTES:**
- 1) FINISH PER TD-09-103 (POWDER COAT), CLASS B, TEXTURE LEVEL 3, - ALL SURFACES UNLESS OTHERWISE NOTED.
 - 2) DIMENSIONS APPLY BEFORE APPLICATION OF FINISH: ADD .005" TO EACH SURFACE FOR INSPECTION.
 - 3) INSTALL THE ITEM #2 WELD STUD ON THE CENTER PUNCH.
 - 4) MASK OFF THE ITEM #2 WELD STUD PRIOR TO FINISHING.
 - 5) TYPICAL BEND RADIUS = 0.030

INTERPRET DRAWING PER ASME Y14.5M-1994
DIMENSIONAL LIMITS APPLY AFTER APPLICATION OF FINISH
DRAWING NOT TO SCALE
TOLERANCE UNLESS OTHERWISE NOTED:
ANGULAR +/- 1°
.XXXX +/- .010
.XXX +/- .015
.XX +/- .030
.X FOR REF. ONLY
UNLESS OTHERWISE SPECIFIED ALL DIMENSIONS ARE IN INCHES

NOTICE:
Use of this document is subject to a confidentiality and nondisclosure agreement with Great Lakes Case & Cabinet Co., Inc. (GLCC) and may not be reproduced, disclosed or utilized in whole or in part without prior written authorization from GLCC.

PART NUMBER:	
QTY PER UNIT:	1
MATERIAL TYPE:	CRS
MATERIAL GAUGE:	16 GA
FINISH:	SEE NOTES
DRAWN	DATE
JL	2/19/2007
CHECKED & APP.	DATE
WSS	2-19-07

TITLE	60"H x 32"D ENHANCED, LIFT-OFF, VENTED SIDE PANEL	
GREAT LAKES CASE & CABINET CO., INC.		
P.O. BOX 551 EDINBORO, PA 16412		
PHONE (814) 734-7303 FAX (814) 734-3907		
E-MAIL glcc@greatcabinets.com		
DWG NO:	REV	
I005053	0	
SHEET: 1 OF 1		

