

REVISION HISTORY			
REV	DESCRIPTION	DATE	APPROVED
0	ECO-03112	1/25/2011	FED

SPECIFICATIONS:

CFM: (235/ FAN) x 2 = 470
 VAC = 115
 Hz = 50/60
 WATTS = 70
 LINE AMPS = 0.61A
 dba = 55

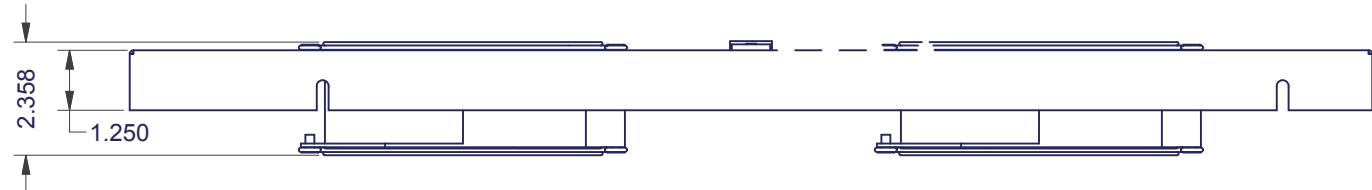
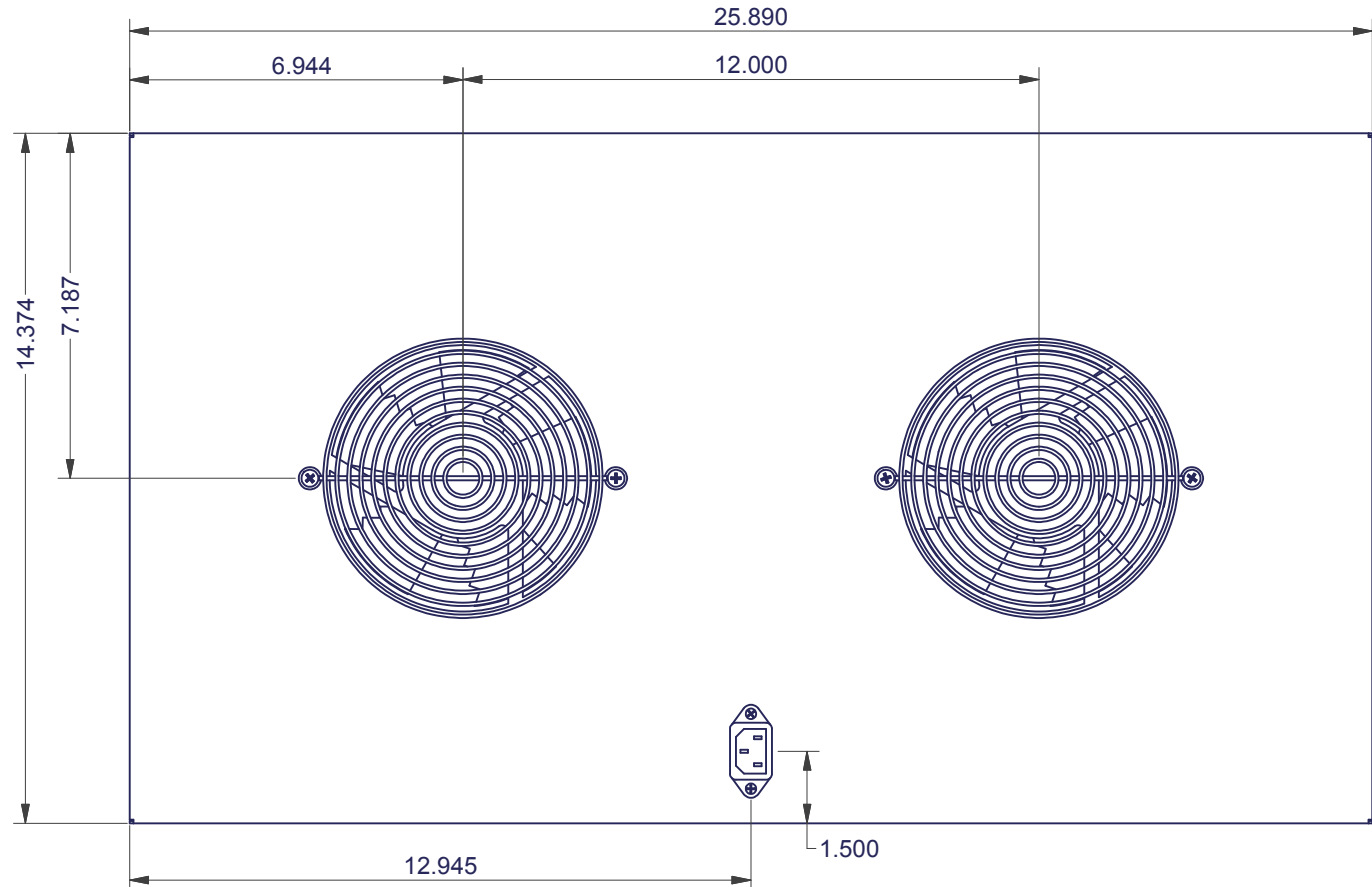
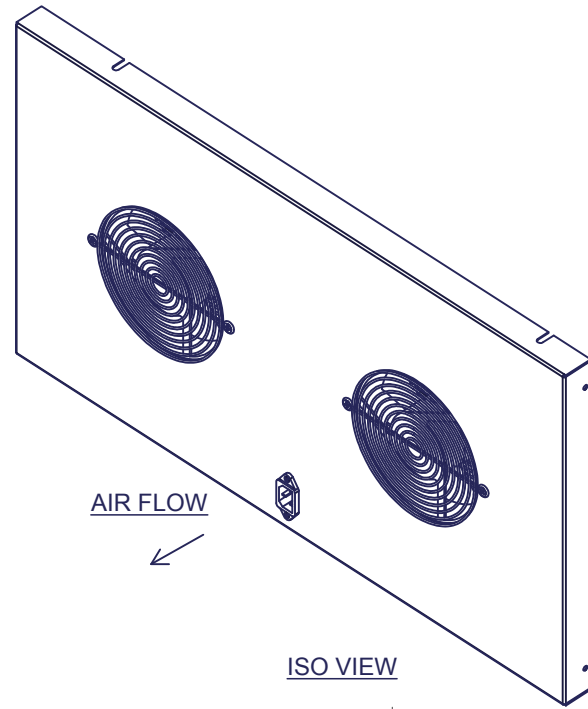

Bill of Material					FILE NAME	REVISION
ITEM	PART NUMBER	STOCK NUMBER	QTY	DESCRIPTION		
5	ADFTES3042X100		1	AIR DEVERTER FAN TRAY FOR 30"W x 42"D ES BOTTOM PANEL	I007468.ipt	0
1	OA172SAP-11-1		2	ORION 235 CFM FAN, 110V - KNIGHT ELECTRONICS	OA172SAP-11-1.ipt	
2	G172-10HA		4	FINGER GUARD, 172 SERIES FANS, BLACK	G172-10HA.ipt	
3	H01-069	H01-069	8	SCREW, 10-32x3/8" PH FLAT TYPE 23 BLACK OXIDE/WAX RoHS (SCR1032X375FHBLK23)	H01-069.ipt	
4	07071CW		1	IEC CONNECTOR - ARCO	07071CW.ipt	
6	0404RPF		2	#4-40 x 1/4" TAPTITE PHIL FLAT HD ZN. PL. SCREW	0404RPF.ipt	
7	H01-078	H01-078	4	SCREW, 10-32x1/2" PH PAN TYPE 23 BLACK OXIDE/WAX RoHS (SCR1032X500BLK)	H01-078.ipt	
8	GASKET 0.500 x0.0625		5'-9"	1/16" x 1/2" NEOPRENE GASKET w/ PSA		
9	C45-2DCT		1	2 FAN POWER WIRING HARNESS ASSEMBLY (KNIGHT)		
10	XF34		1	2 FAN GROUNDING WIRING HARNESS ASSEMBLY		
11	XF0312IEC		1	12 FOOT POWER CORD, NEMA 5-15 PLUG		

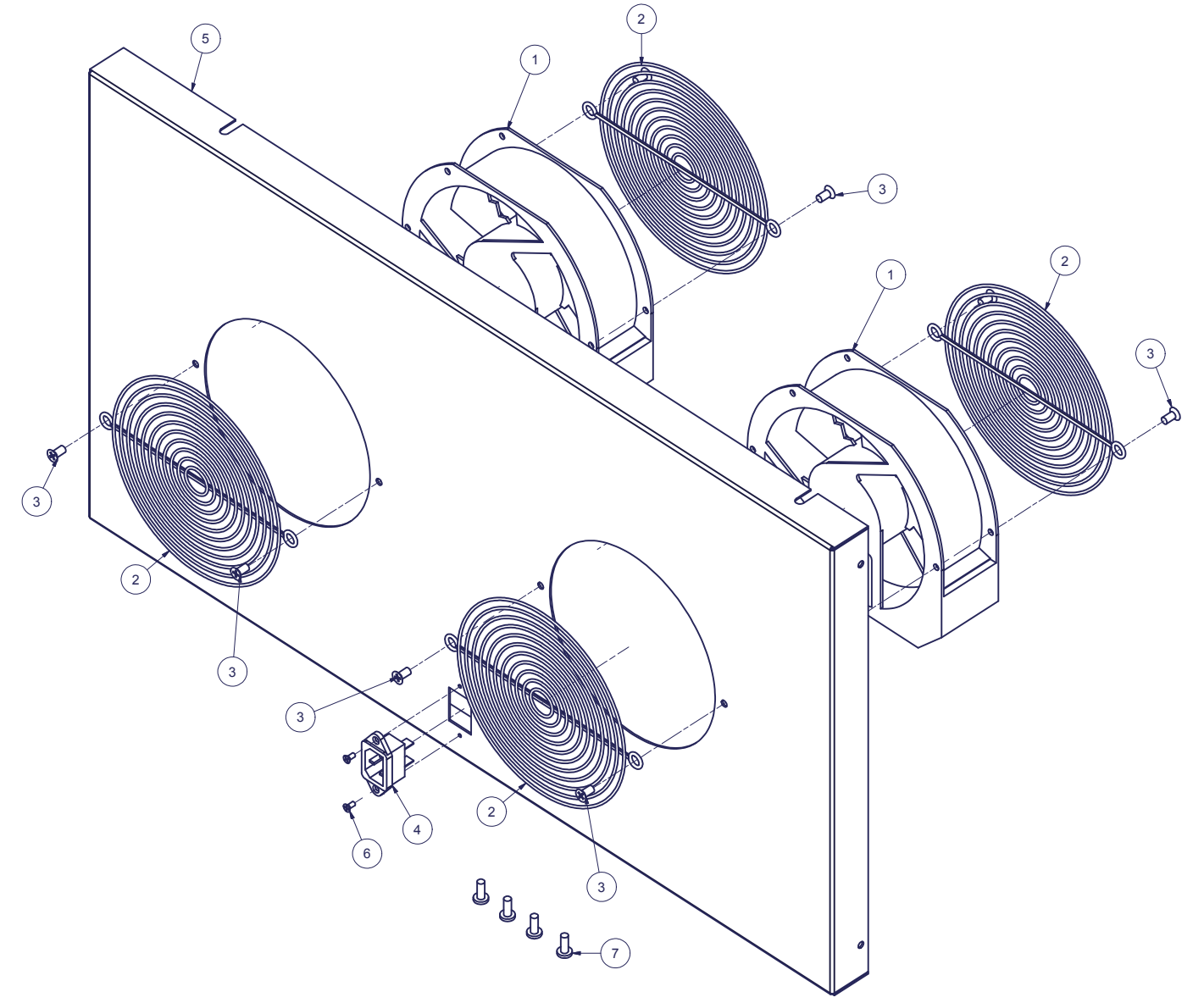

8 PLACE GASKET ON ALL SIDES ALONG THE BOTTOM EDGE ON THE OUTSIDE AS SHOWN. DO NOT COVER HOLES w/ GASKETING!

INTERPRET DRAWING PER ASME Y14.5M-1994
 DIMENSIONAL LIMITS APPLY AFTER APPLICATION OF FINISH
 DRAWING NOT TO SCALE
 TOLERANCE UNLESS OTHERWISE NOTED:
 ANGULAR +/- .1"
 .XXXX +/- .010
 .XXX +/- .015
 .XX +/- .030
 X FOR REF. ONLY
 UNLESS OTHERWISE SPECIFIED ALL DIMENSIONS ARE IN INCHES

NOTICE:
 Use of this document is subject to a confidentiality and nondisclosure agreement with Great Lakes Case & Cabinet Co., Inc. (GLCC) and may not be reproduced, disclosed or utilized in whole or in part without prior written authorization from GLCC.

PART NUMBER: **ADFTES3042**
 QTY PER UNIT: 1
 MATERIAL TYPE: CRS
 MATERIAL GAUGE: 16 GA
 FINISH: POWDERCOAT
 DRAWN CD DATE 9/20/2008
 CHECKED & APP. WSS DATE 1/25/2011

TITLE: **AIR DIVERTER FAN TRAY FOR 30"W x 42"D 'ES' BOTTOM PANEL - TOP LEVEL**
 GREAT LAKES CASE & CABINET CO., INC.
 P.O. BOX 551 EDINBORO, PA 16412
 PHONE (814) 734-7303 FAX (814) 734-3907
 E-MAIL glcc@greatcabinets.com
 DWG NO: **ADFTES3042** REV: **0** SHEET: 1 OF 1